

Power Line Communication Coupling Transformers



Introduction

The PLC (Power Line Communication) will become one of the most interesting and various applications in the next few years. AMR (Automatic Meter Reading) for energy meters, water meters, gas meters, etc will become very important for controlling and economical use of our resources world wide. With PLC it can give the end-user a constant overview about its consumption and the possibility to plan it economical. The general energy suppliers have the opportunity to control user-groups up to a single end-user in short time-steps up to online. They can reduce the energy spikes up to a harmonic operation of their power stations. Home automatisaton and PC home networking will be an additional application for PLC. The cooperation between the domestic appliances and the energy meters will make the economical use perfect. PC home networking will be in competition with the wireless applications.

For PLC it's necessary to have a coupling transformer for the data transmission between the electric cabeling and the transceiver. Its inductance has a value between 10 μ H ... 2 mH and its electrical insulation depends on its application. The capacitor in the system is for blocking the 50 or 60Hz frequency currents.

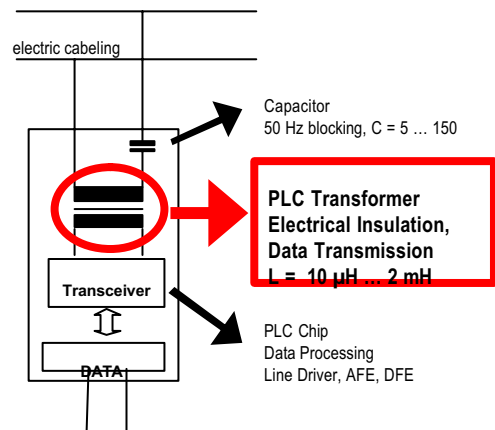

Based on our own developed and produced amorphous material VAC offers a complete product range of PLC coupling transformer for different low and high bit rate chipsets. Please look at the internet pages at www.vacuumschmelze.com in the telecommunication/powerline pages and find your used PCL chipset and we will present you our PLC transformers in different designs. Beside the standard PLC transformer VAC also develops PLC transformer with individual requirements. The PLC transformers are manufactured by VAC in process and cost optimized plants. Our in-depth knowledge of the application fields and technical requirements puts us in a position to find the ideal solution and turn this into a competitive product.

VAC's own developed and produced amorphous material VITROVAC or VITROPERM is an excellent substance for the core of a PLC transformer. One of the main advantages is shown in the following diagram. The saturation in comparison to a PLC transformer based on ferrite is significant. At $I_{ac}=45\text{mA}$ the VAC PLC transformer based on VITROVAC has 1,6mH the version based on ferrite on 0,2mH. This shows that the PLC transformer based on ferrite is in saturation and produces high harmonic distortion, especially 50 Hz distribution. On the other hand the VAC PLC transformer meets the target.

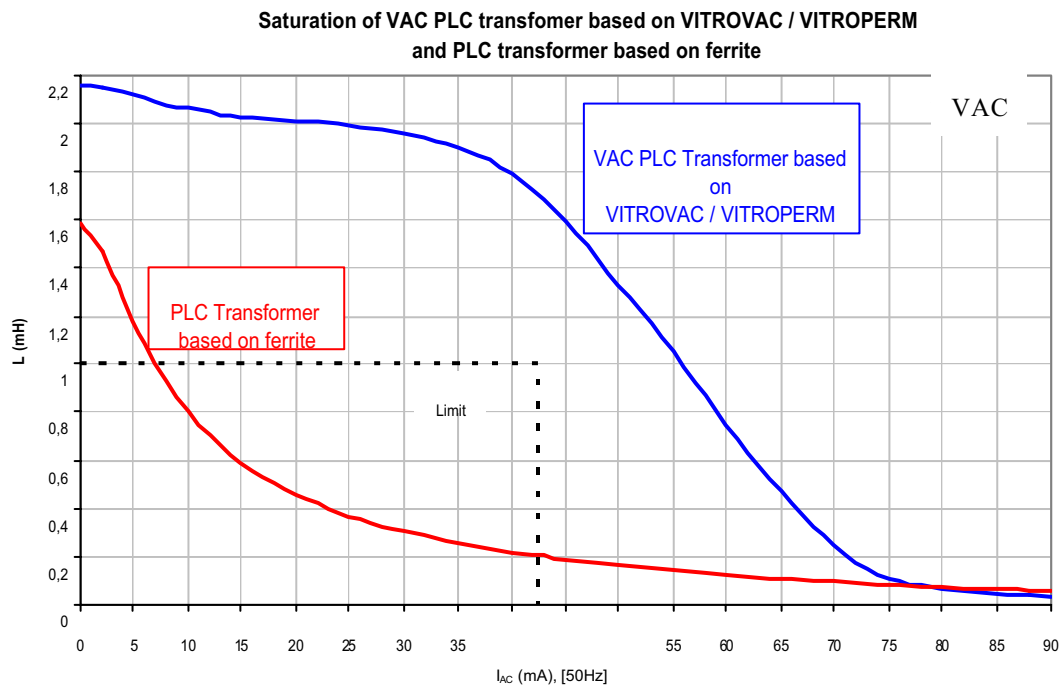

The advantages of VAC PLC coupling transformers are:

- Excellent transmission characteristics
- Low insertion loss
- Low THD, especially low 50Hz distortion
- Matching transformer for leading IC's
- Insulation according to EN 60950 / UL 1950
- Compact designs
- Compliance with all PLC standards, Homeplug 1.0, EIA 709.2, CENELEC EN 50065-1, and CEA R7.3